

26-FF

PLAN NO. PGP35403

Deposited in the Land Title Office at Prince George this 11th day of June 1991.

W. G. Standy
REGISTRAR

PLAN OF STATUTORY RIGHT OF WAY
WITHIN BLOCK B, PLAN 1160,
DISTRICT LOT 4376, CARIBOO DISTRICT.

B.C.G.S. 936.097

Scale: 1 : 750 (Distances are in metres)



Bearings are astronomic, derived from Plan 20750

LEGEND

- PCOn Denotes Standard Concrete Post
- IP Denotes Standard Iron Post
- Wt Denotes Witness
- Denotes Old
- th Denotes Traverse Hub

BOOK OF REFERENCE	
DESCRIPTION	AREA
Block B, D.L. 4376, Plan 1160	1.338ha

I, Dale L. Keown, a British Columbia Land Surveyor of Prince George in British Columbia, certify that I was present at and personally superintended the survey represented by this plan and that the survey and plan are correct. The survey was completed on the 2nd day of October, 1990.

Dale Keown
Dale L. Keown, B.C.L.S.

I hereby certify that this is a true copy of the Official Plan on deposit with the Surveyor General, Ministry of Crown Lands, and numbered Plan 13 Tube 1543
For Deputy Surveyor General
Victoria, B.C. May 16, 1991

This plan lies within the Fraser-Fort George Regional District.

McWilliam, Whyte, Goble & Associates
B.C. Land Surveyors, Prince George
(604) 562-1196 & 564-5322 (fax 562-3656)
Kamloops - Smithers - Williams Lake

F.B.- SR2-6 D.L.- 4376 REF. NO.- 69626

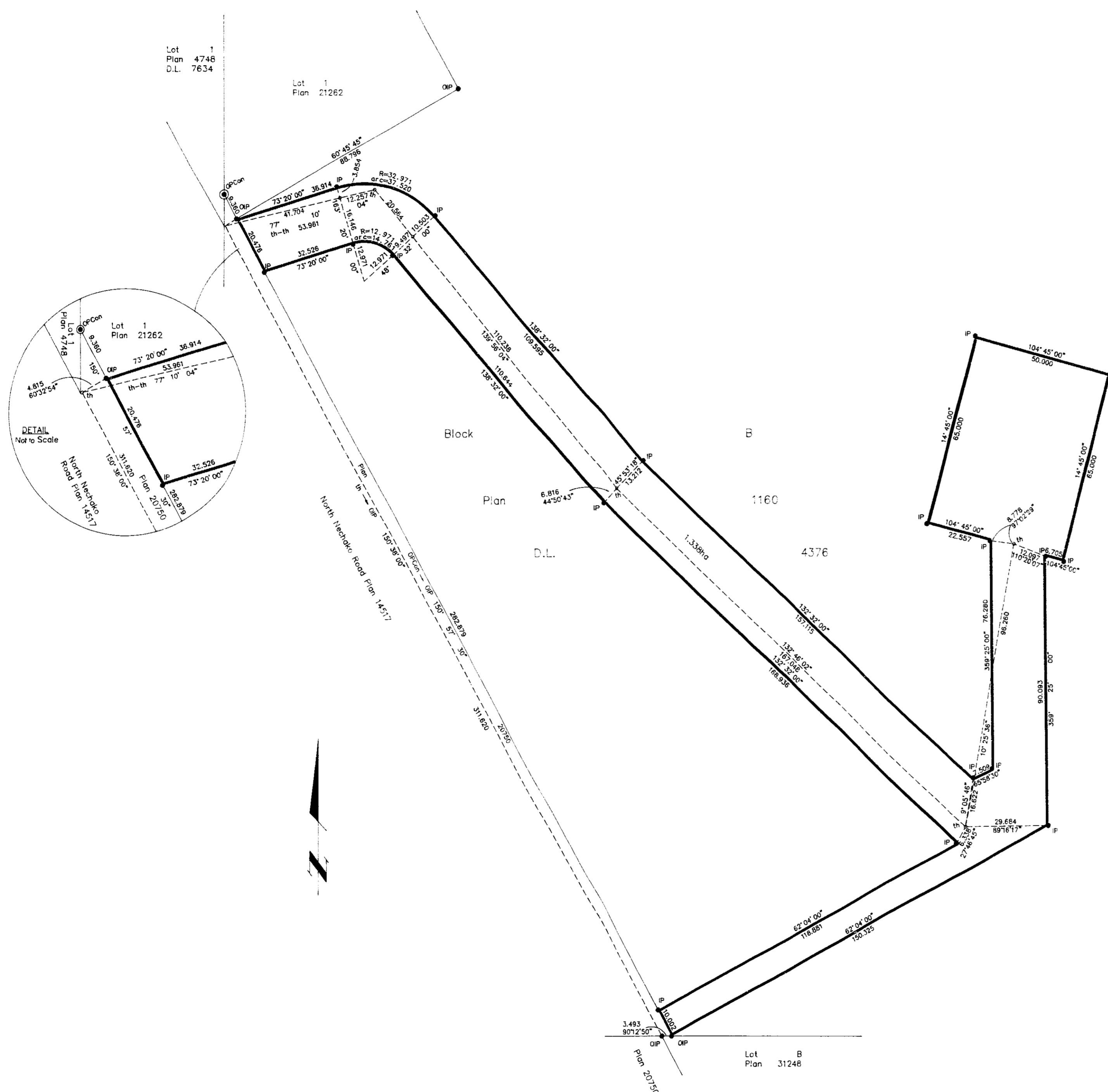

Lot 1
Plan 4748
D.L. 7634

Lot 1
Plan 21262

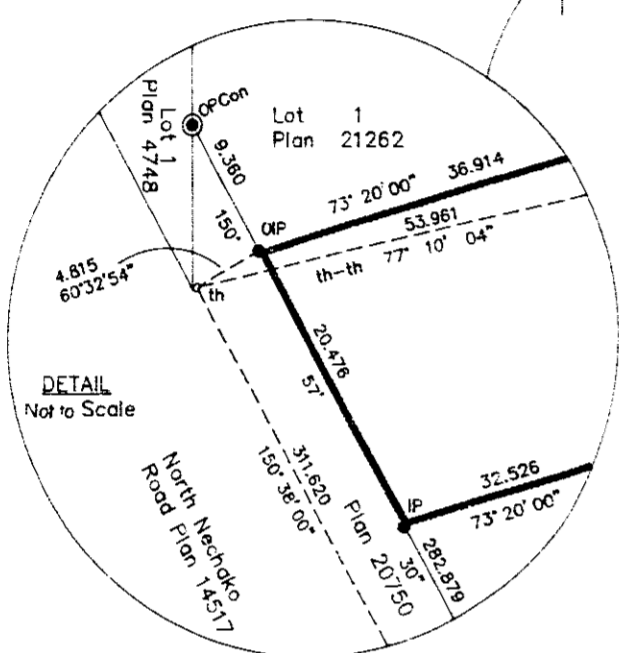

Lot B
Plan 31248