

STRATA PLAN OF LOT 24, DISTRICT LOT 2014, CARIBOO DISTRICT, PLAN EPP16518.

PLAN EPS4537

INTEGRATED SURVEY AREA No. 39 PRINCE GEORGE, BC, NAD83 (CSRS) 4.0.0.BC.1

BCGS 93G.087



THE INTENDED PLOT SIZE OF THIS PLAN IS 280mm IN WIDTH BY 432mm IN HEIGHT (B SIZE) WHEN PLOTTED AT A SCALE OF 1:300.

ALL DISTANCES ARE IN METRES AND DECIMALS THEREOF.

GRID BEARINGS ARE DERIVED FROM OBSERVATIONS BETWEEN GEODETIC CONTROL MONUMENTS 86H1819 AND 86H1564.

THE UTM COORDINATES AND ESTIMATED HORIZONTAL POSITIONAL ACCURACY ACHIEVED HAVE BEEN DERIVED FROM MASCOT PUBLISHED COORDINATES AND STANDARD DEVIATIONS FOR GEODETIC CONTROL MONUMENTS 86H1819 AND 86H1564.

THIS PLAN SHOWS HORIZONTAL GROUND-LEVEL DISTANCES UNLESS OTHERWISE SPECIFIED. TO COMPUTE GRID DISTANCES, MULTIPLY GROUND-LEVEL DISTANCES BY THE AVERAGE COMBINED FACTOR OF 0.9995088 WHICH HAS BEEN DERIVED FROM CONTROL MONUMENTS 86H1819 AND 86H1564.

LEGEND

SYMBOLS		DESCRIPTION
FOUND	PLACED	
▲		CONTROL MONUMENT
●		STANDARD IRON POST
SL		STRATA LOT
Pt		PART
⊙		COMMON PROPERTY
LCP		LIMITED COMMON PROPERTY
NON-H		NON-HABITABLE
CSF		COMBINED SCALE FACTOR
EHPA		ESTIMATED HORIZONTAL POSITIONAL ACCURACY

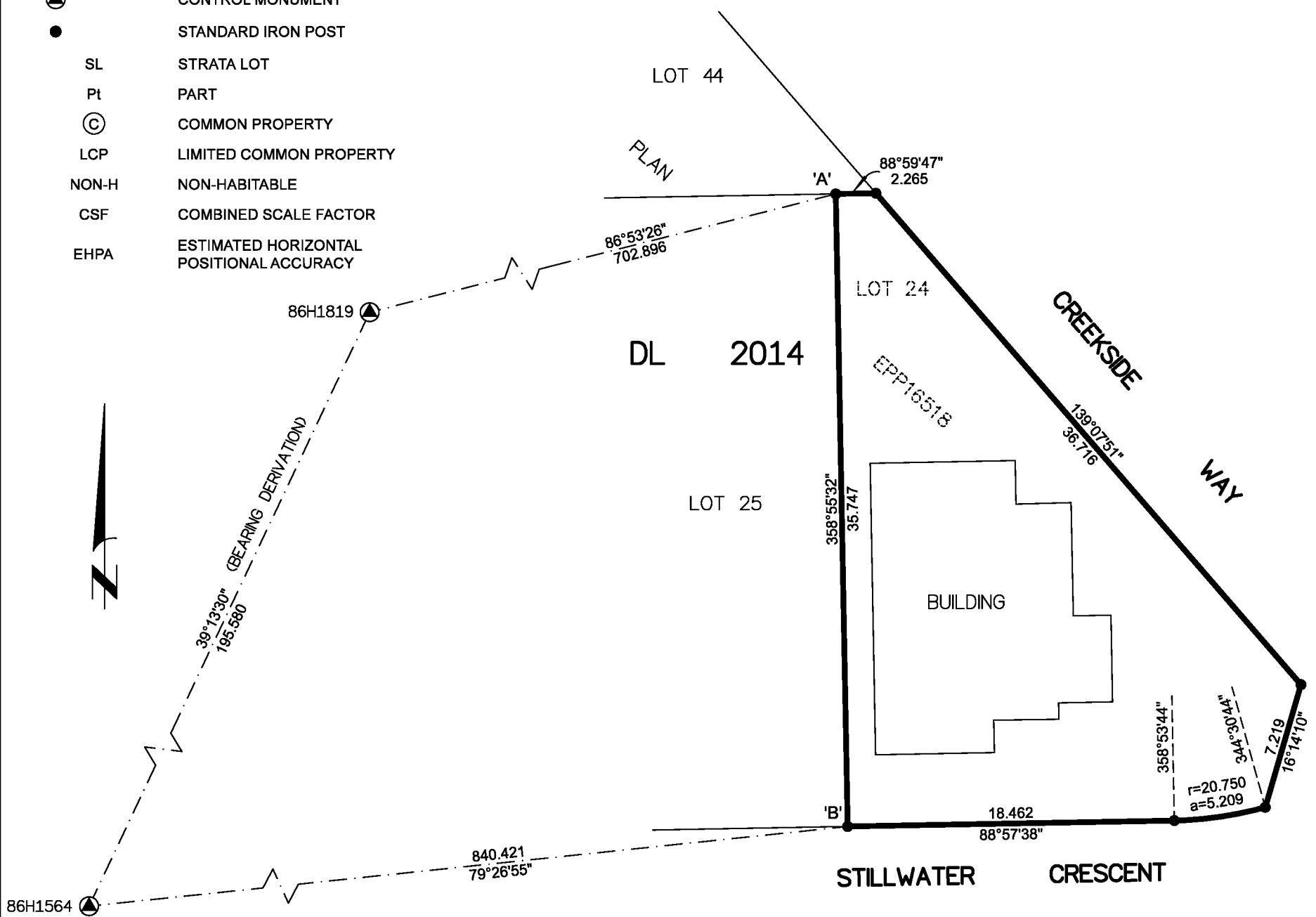

GEOREFERENCING POSITIONS UTM COORDINATES, ZONE 10, NAD 83 (CSRS), 4.0.0.BC.1				
STATION	NORTHING	EASTING	EHPA	CSF
FDIP 'A'	5967233.91	516458.48	0.10	0.9995088
FDIP 'B'	5967198.18	516459.15	0.10	0.9995088

THE ASSOCIATION OF BC LAND SURVEYORS HAS GRANTED RELIEF FROM COMPLIANCE WITH GSI RULE 5-4(2) FOR THIS SURVEY SINCE THE STANDARD DEVIATIONS OF THE ISA MONUMENTS DO NOT MEET THE REQUIREMENTS OF SAID RULE.

THE FIELD SURVEY REPRESENTED BY THIS PLAN WAS COMPLETED ON THE 7th DAY OF JULY, 2017
SHAUNA C. GOERTZEN, BCLS 798

THIS PLAN LIES WITHIN THE CITY OF PRINCE GEORGE.
THIS PLAN LIES WITHIN THE REGIONAL DISTRICT OF FRASER-FORT GEORGE.

NOTES:

OFFSETS SHOWN ARE TO THE EXTERIOR FOUNDATION WALL UNLESS OTHERWISE NOTED.

ALL ANGLES DEFLECT BY MULTIPLES OF 90° UNLESS OTHERWISE INDICATED.

THE BUILDING IN THIS STRATA PLAN HAVE NOT BEEN PREVIOUSLY OCCUPIED.

THE BUILDINGS SHOWN HEREON ARE WITHIN THE EXTERNAL BOUNDARIES OF THE LAND THAT IS THE SUBJECT OF THE STRATA PLAN.

CIVIC ADDRESS:

SL1 7685 CREEKSIDE WAY, PRINCE GEORGE BC

SL2 8088 STILLWATER CRESCENT, PRINCE GEORGE BC



McELHANNEY ASSOCIATES
LAND SURVEYING LTD.

Suite 12
556 North Nechako Road
Prince George BC
Canada V2K 1A1
Tel 250 561 2229

File No. 2341-6594-ST-1

BUILDING FOUNDATION

PLAN EPS4537



THE INTENDED PLOT SIZE OF THIS PLAN IS 280mm IN WIDTH BY 432mm IN HEIGHT (B SIZE) WHEN PLOTTED AT A SCALE OF 1:150.

ALL DISTANCES ARE IN METRES AND DECIMALS THEREOF.

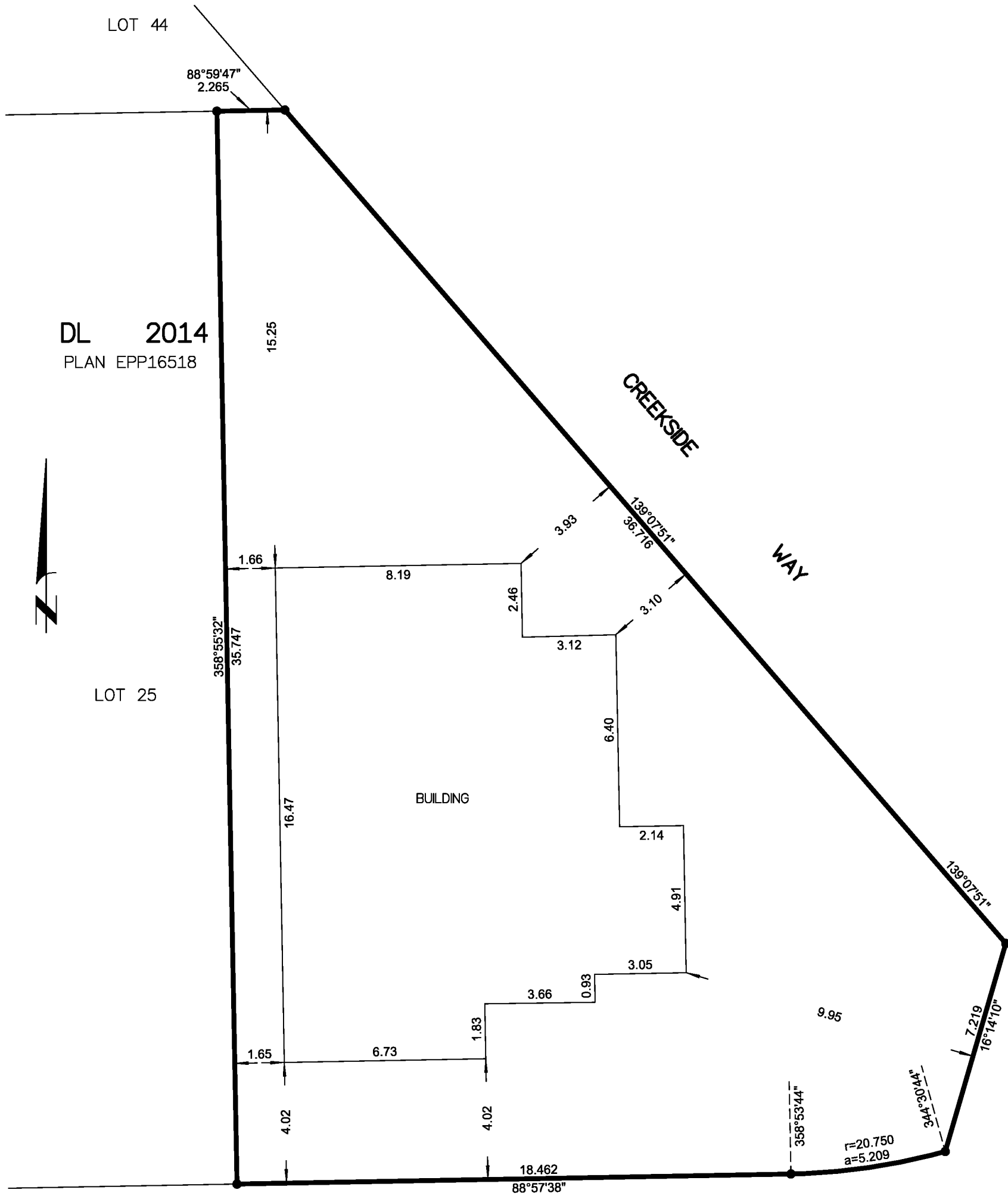

DL 2014
PLAN EPP16518



<p>NOTE: OFFSET DIMENSIONS ARE TO EXTERIOR OF FOUNDATION WALL AND ARE PERPENDICULAR TO PROPERTY LINES, UNLESS OTHERWISE SHOWN.</p>	<p>STILLWATER CRESCENT</p>	<p>McElhanney McELHANNEY ASSOCIATES LAND SURVEYING LTD. Suite 12 556 North Nechako Road Prince George BC Canada V2K 1A1 Tel 250 561 2229</p>
<p>SHAUNA C. GOERTZEN, BCLS 798 AUGUST 21, 2017</p>		<p>File No. 2341-6594-ST-2</p>

GROUND FLOOR

PLAN EPS4537



THE INTENDED PLOT SIZE OF THIS PLAN IS 280mm IN WIDTH BY 432mm IN HEIGHT (B SIZE) WHEN PLOTTED AT A SCALE OF 1:150.

ALL DISTANCES ARE IN METRES AND DECIMALS THEREOF.

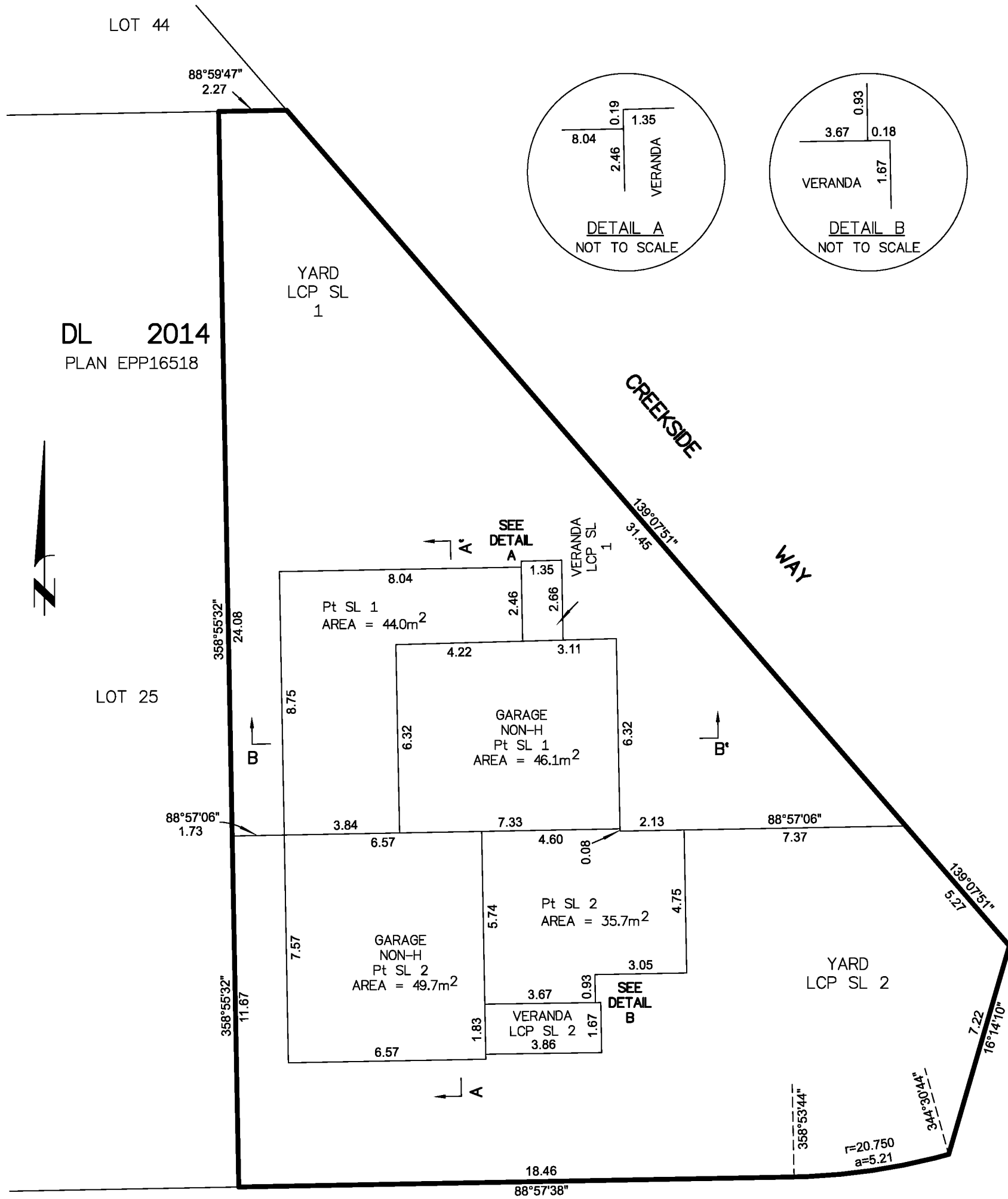

NOTES:
THIS SHEET SHOWS DIMENSIONS TO THE CENTRELINE OF ALL WALLS.

SECTION ARROWS ON THIS PLAN POINT IN THE DIRECTION OF THE VIEW.

SHAUNA C. GOERTZEN, BCLS 798
AUGUST 21, 2017

McElhanney
McELHANNEY ASSOCIATES
LAND SURVEYING LTD.
Suite 12
556 North Nechako Road
Prince George BC
Canada V2K 1A1
Tel 250 561 2229

File No. 2341-6594-ST-3

SECOND FLOOR

PLAN EPS4537



THE INTENDED PLOT SIZE OF THIS PLAN IS 280mm IN WIDTH BY 432mm IN HEIGHT (B SIZE) WHEN PLOTTED AT A SCALE OF 1:150.

ALL DISTANCES ARE IN METRES AND DECIMALS THEREOF.

LOT 44

DL 2014
PLAN EPP16518



LOT 25

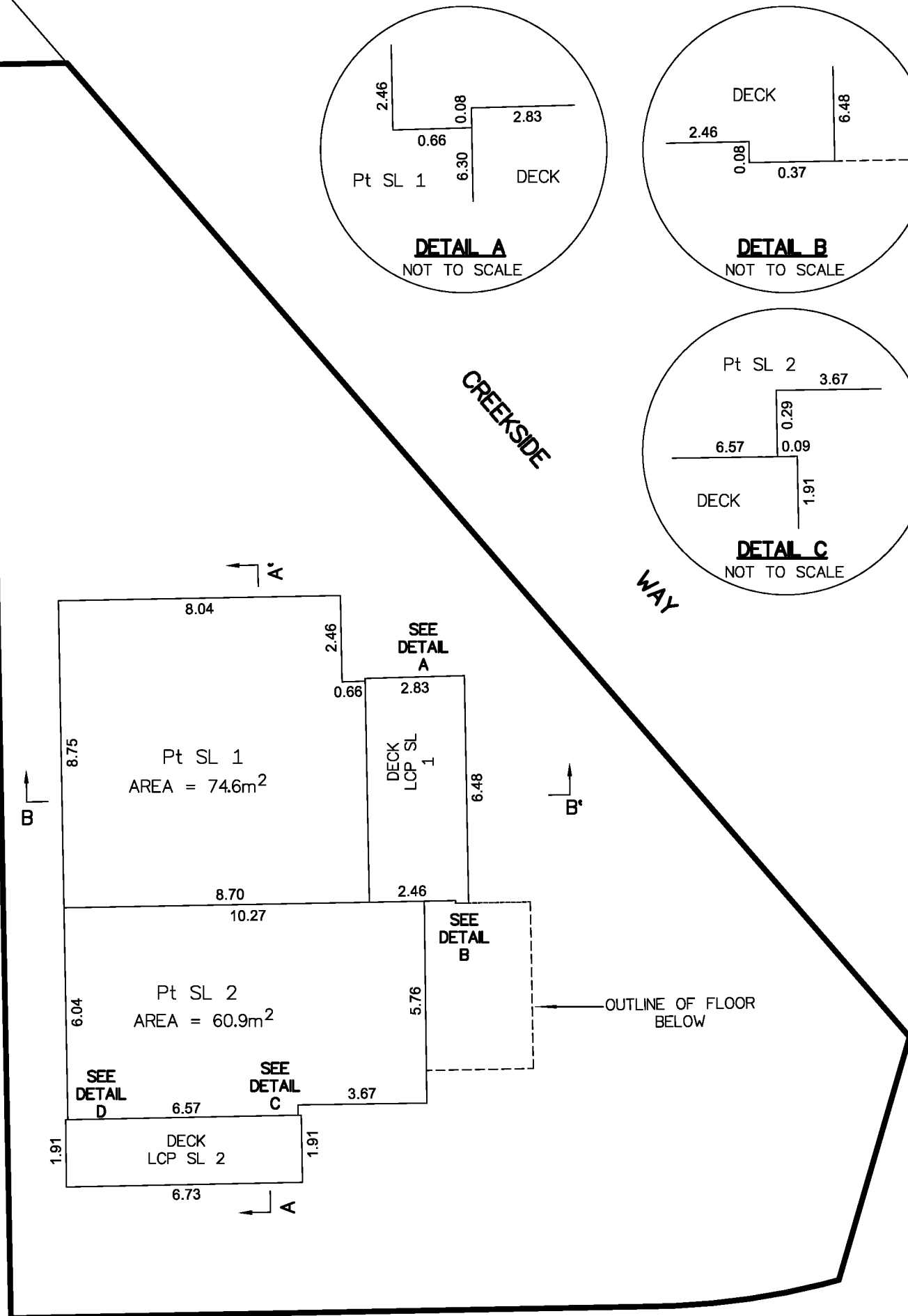
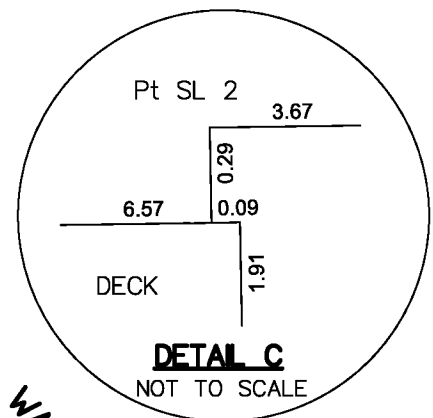
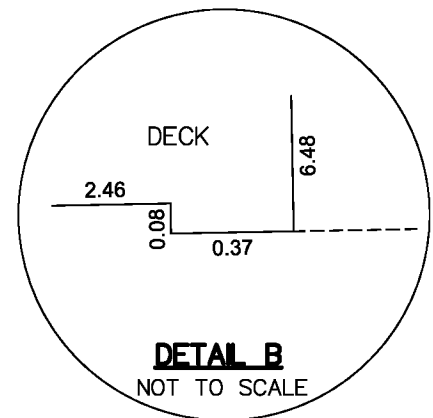
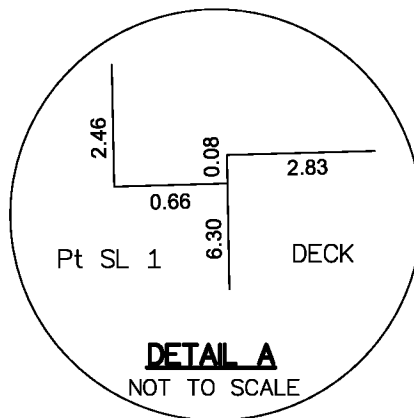
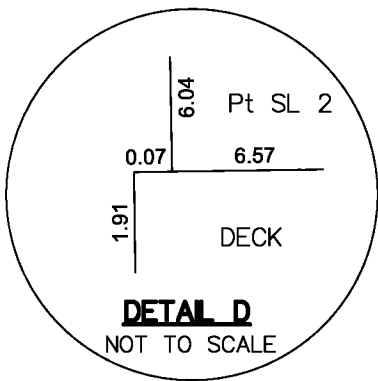

CREEKSIDE

WAY

STILLWATER

CRESCENT

NOTES:
THIS SHEET SHOWS DIMENSIONS TO THE CENTRELINE OF ALL WALLS.

SECTION ARROWS ON THIS PLAN POINT IN THE DIRECTION OF THE VIEW.

SHAUNA C. GOERTZEN, BCLS 798
AUGUST 21, 2017

McElhanney
McELHANNEY ASSOCIATES
LAND SURVEYING LTD.
Suite 12
556 North Nechako Road
Prince George BC
Canada V2K 1A1
Tel 250 561 2229

File No. 2341-6594-ST-4

THIRD FLOOR

SHEET 5 OF 6

PLAN EPS4537



THE INTENDED PLOT SIZE OF THIS PLAN IS 280mm IN WIDTH BY 432mm IN HEIGHT (B SIZE) WHEN PLOTTED AT A SCALE OF 1:150.

ALL DISTANCES ARE IN METRES AND DECIMALS THEREOF.

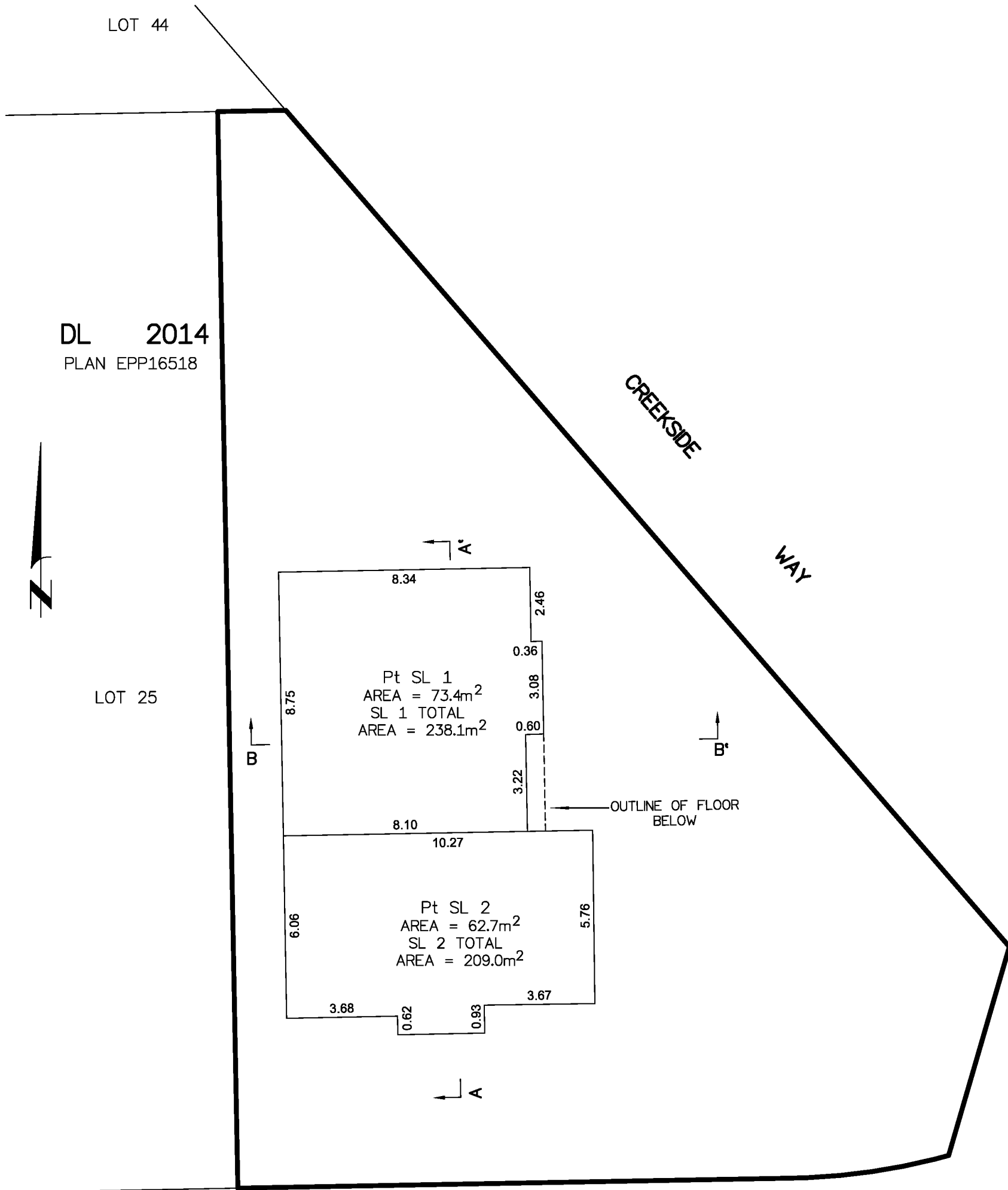

NOTES:
THIS SHEET SHOWS DIMENSIONS TO THE CENTRELINE OF ALL WALLS.

SECTION ARROWS ON THIS PLAN POINT IN THE DIRECTION OF THE VIEW.

SHAUNA C. GOERTZEN, BCLS 798
AUGUST 21, 2017

McElhanney
McELHANNEY ASSOCIATES
LAND SURVEYING LTD.
Suite 12
556 North Nechako Road
Prince George BC
Canada V2K 1A1
Tel 250 561 2229

File No. 2341-6594-ST-5

SECTIONS

PLAN EPS4537



THE INTENDED PLOT SIZE OF THIS PLAN IS 280mm IN WIDTH BY 432mm IN HEIGHT (B SIZE) WHEN PLOTTED AT A SCALE OF 1:150.

ALL DISTANCES ARE IN METRES AND DECIMALS THEREOF.

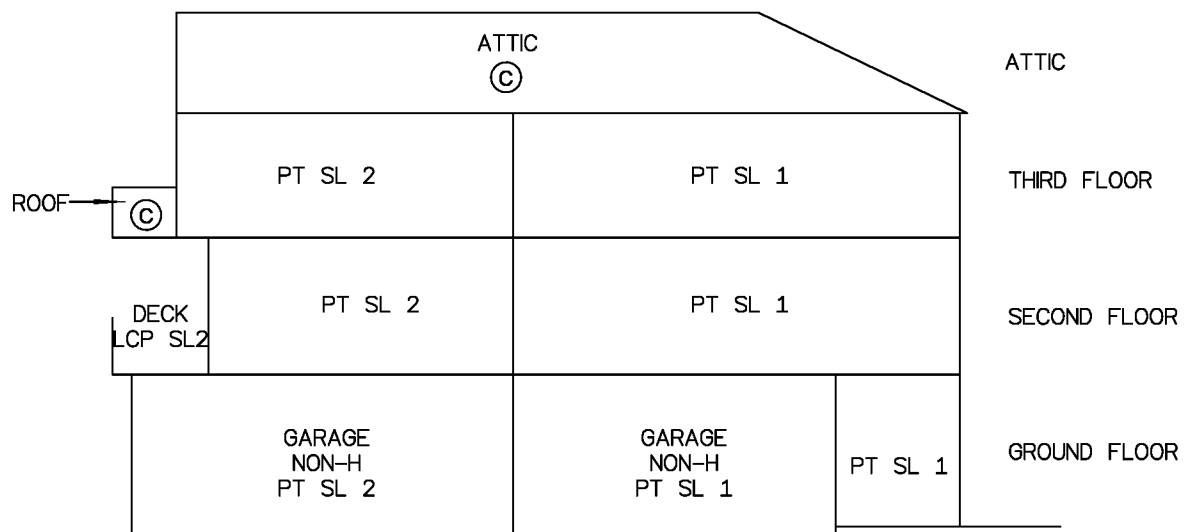

SECTION A-A'

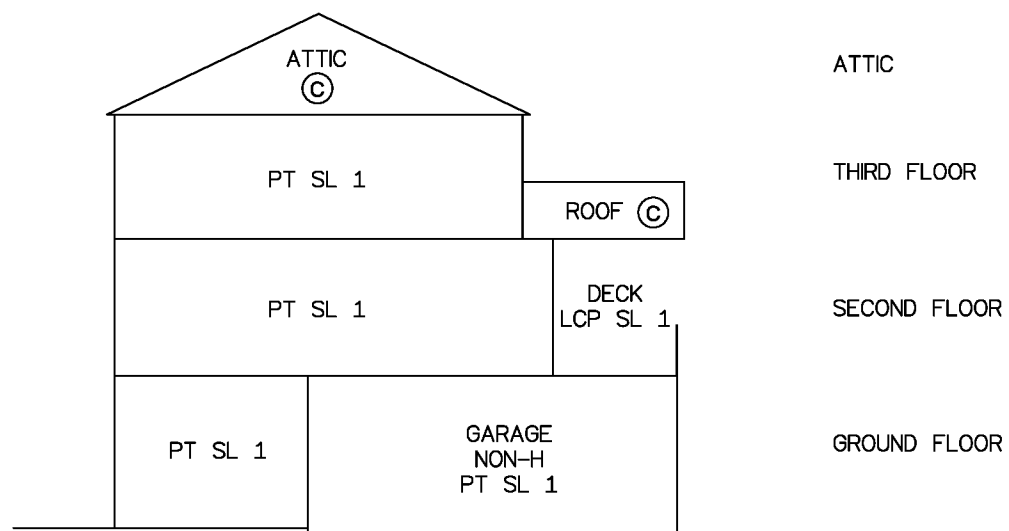

SECTION B-B'