

# EXPLANATORY PLAN OF EASEMENT OVER PART OF LOT A, DISTRICT LOT 2423, CARIBOO DISTRICT, PLAN EPP35822.

## PLAN EPP64221

✓ CORRECTED THIS 30TH DAY OF SEPTEMBER,  
2016; SEE CA5543373 ✓

PURSUANT TO SECTION 99(1)(a) OF THE LAND TITLE ACT.

**BCGS 931.006**

INTEGRATED SURVEY AREA No. 39, PRINCE GEORGE, NAD83 (CSRS)

ALL DISTANCES ARE HORIZONTAL GROUND-LEVEL AND ARE SHOWN IN METRES AND DECIMALS THEREOF, UNLESS OTHERWISE INDICATED.



THE INTENDED PLOT SIZE OF THIS PLAN IS 432mm IN WIDTH BY 280mm IN HEIGHT (B SIZE) WHEN PLOTTED AT A SCALE OF 1:1500

GRID BEARINGS ARE DERIVED FROM PREVIOUSLY INTEGRATED PLAN EPP35822.

THIS PLAN SHOWS HORIZONTAL GROUND-LEVEL DISTANCES, UNLESS OTHERWISE SPECIFIED. TO COMPUTE GRID DISTANCES, MULTIPLY GROUND-LEVEL DISTANCES BY THE AVERAGE COMBINED FACTOR OF 0.9994822. THE AVERAGE COMBINED FACTOR HAS BEEN DERIVED FROM GEODETIC CONTROL MONUMENTS 86H1633 AND 86H1588.

THE UTM COORDINATES AND ESTIMATED HORIZONTAL POSITIONAL ACCURACY ACHIEVED ARE DERIVED USING NATURAL RESOURCES CANADA PRECISE POINT POSITIONING SERVICE.

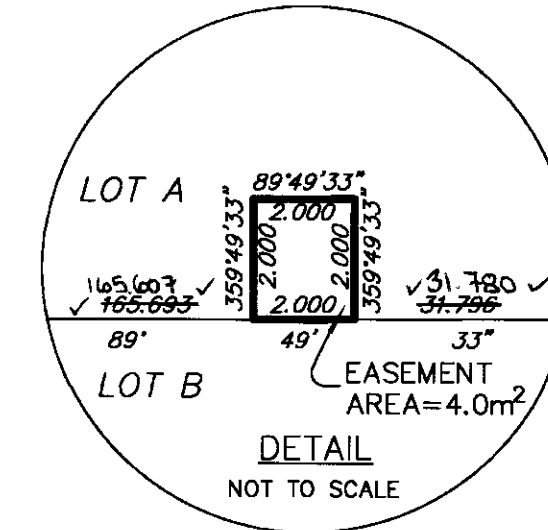
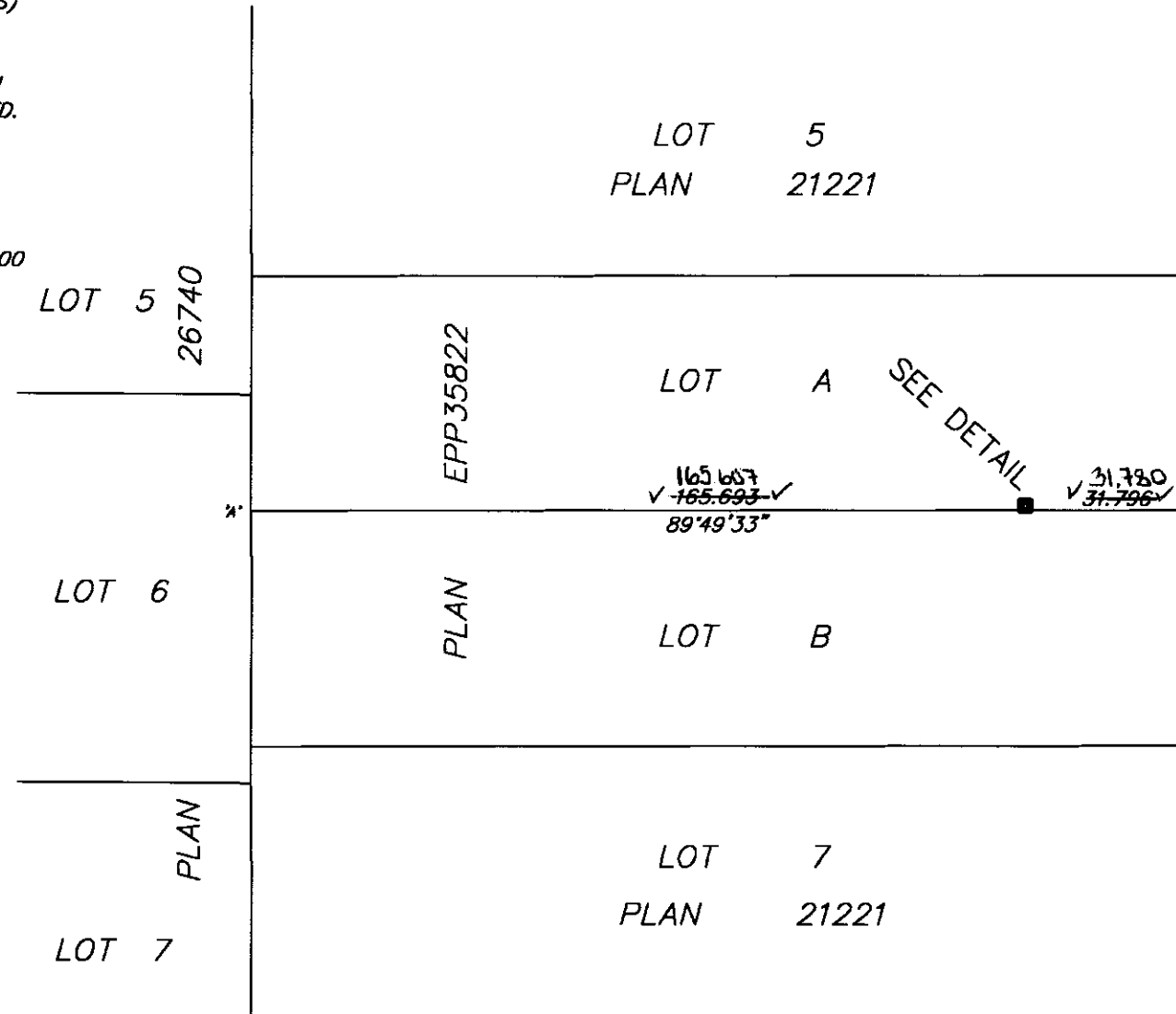

GEOREFERENCING POSITIONS UTM COORDINATES, ZONE 10, NAD 83 (CSRS), 2002.0			
STATION	NORTHING	EASTING	ESTIMATED HORIZONTAL POSITIONAL ACCURACY
'A'	5084077.12	508817.92	0.07m
'B'	5084077.72	510017.31	0.07m

THIS PLAN IS BASED ON THE FOLLOWING LAND TITLE AND SURVEY AUTHORITY OF BC RECORDS: PLAN EPP35822.  
SHAUNA C. GOERTZEN. BCLS 798  
14th DAY OF JULY, 2016

THIS PLAN LIES WITHIN THE REGIONAL DISTRICT OF FRASER - FORT GEORGE.

**McElhanney**

McElhanney Associates  
Land Surveying Ltd.

Prince George, B.C.

E-mail: [pgmats@mcelhanney.com](mailto:pgmats@mcelhanney.com)

Ph: (250) 561-2229 Fax: (250) 563-1941

DL-2423

File No. - 5663-E

July 14 2016